

Control Wiring Diagram

YS12

Table of contents

YS12

- P.1 Over view
- P.2 Control box
- P.3 I/O conveyor -1-
- P.4 I/O conveyor -2-
- P.5 I/O conveyor -3-
- P.6 Head Servo Unit
- P.7 Multi camera unit sel. (option)
- P.8 Operation panel sel.
- P.9 FIX60 feeder structure
- P.10 FES24 feeder structure
- P.11 Ionizer assy option
- P.12 Power transformer
- P.13 Power circuit
- P.14 Emergency circuit
- P.15 Air circuit (YS12)FES
- P.16 Air circuit (YS12)
- P.17 Wiring parts list

OVER VIEW

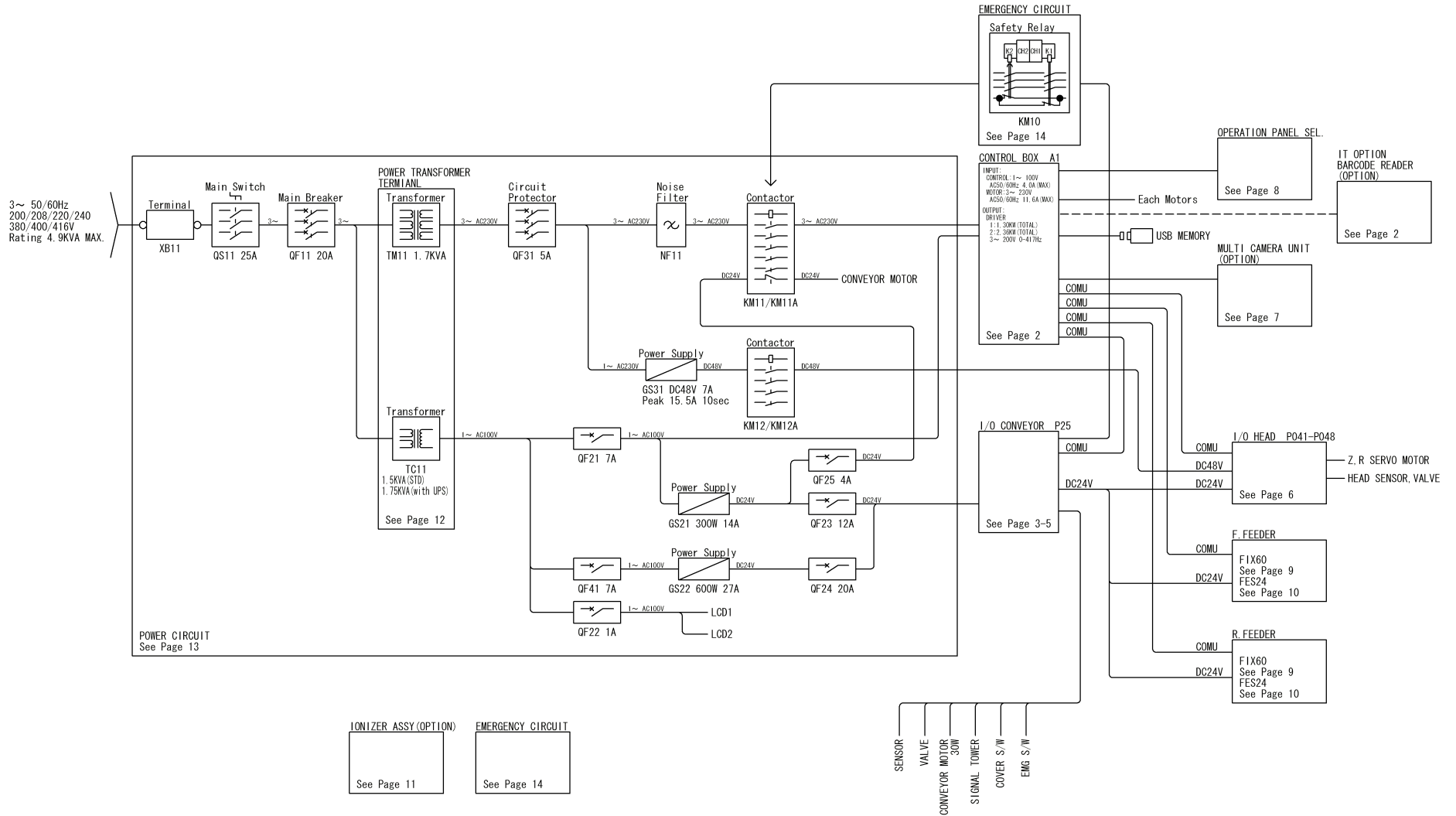

CONTROL BOX

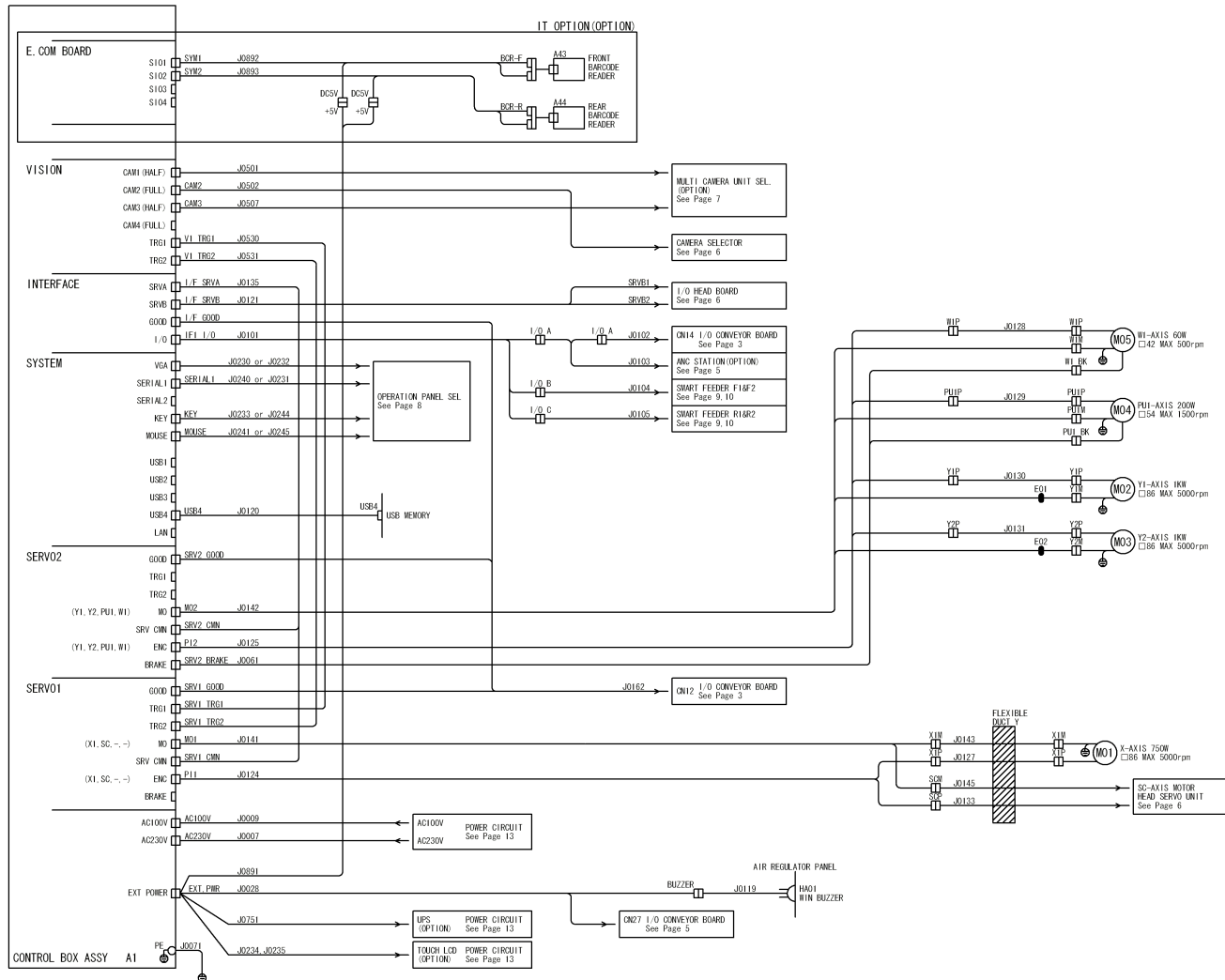

HEAD SERVO UNIT

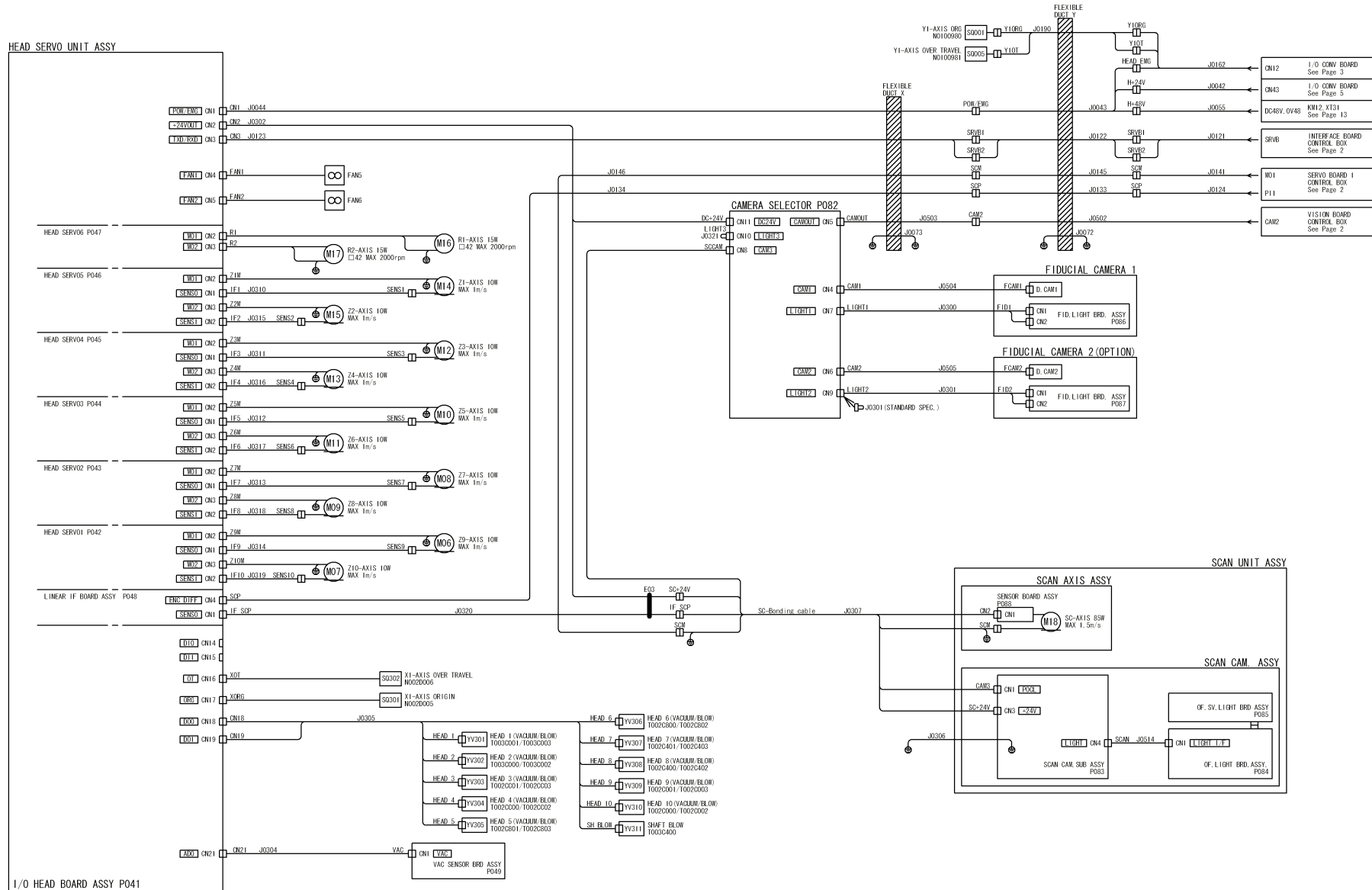

MULTI CAMERA UNIT SEL. (OPTION)

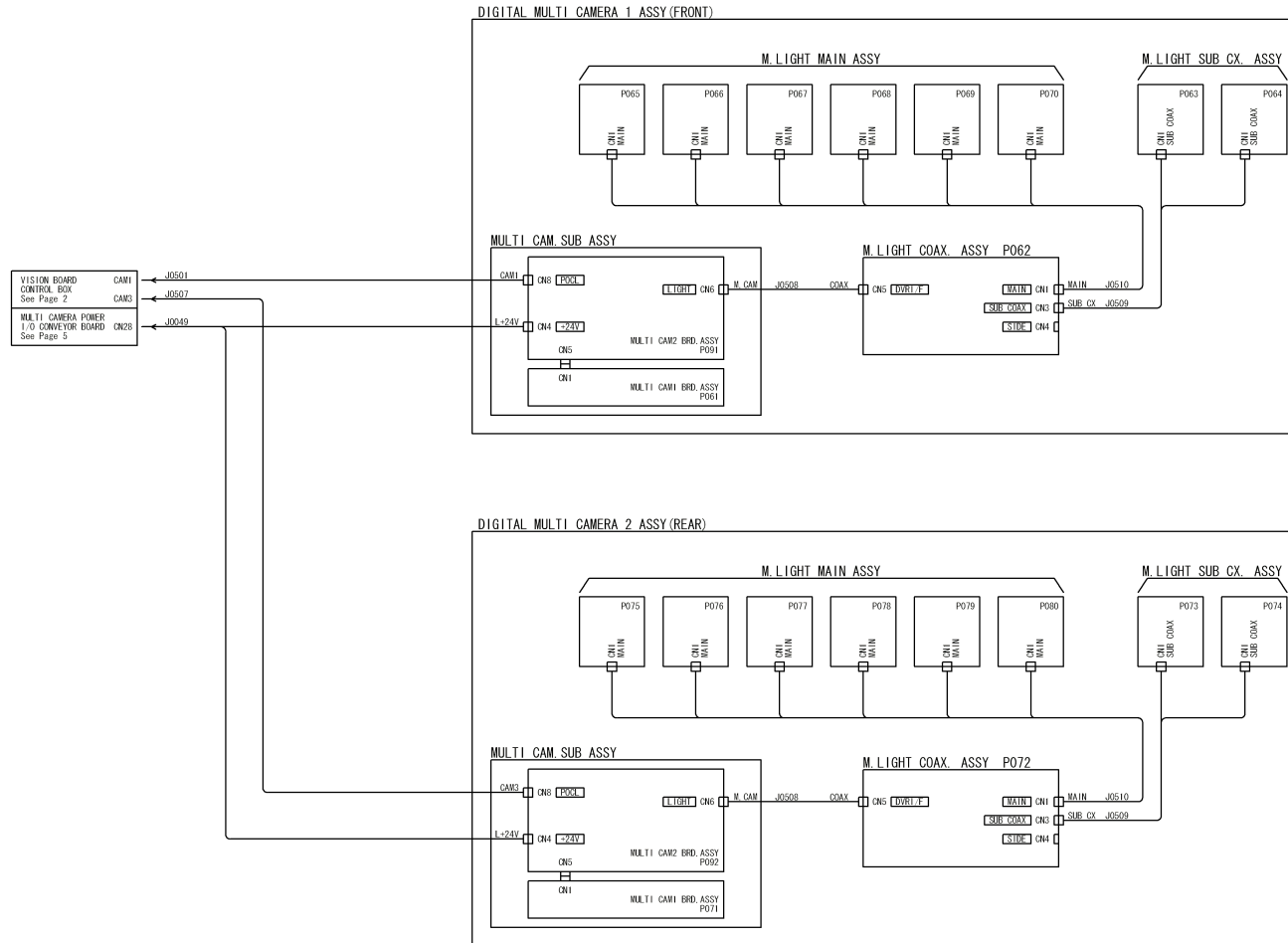

OPERATION PANEL SEL.

FRONT LCD (STANDARD)

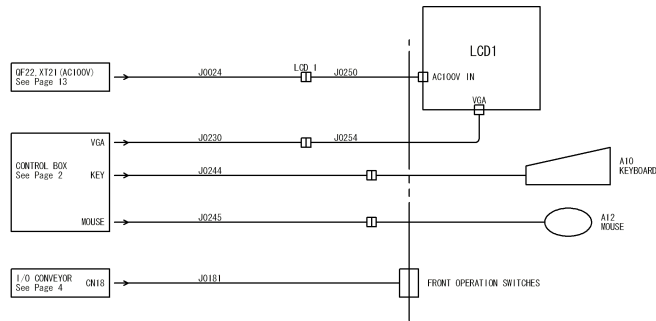

FRONT LCD TOUCH PANEL (OPTION)

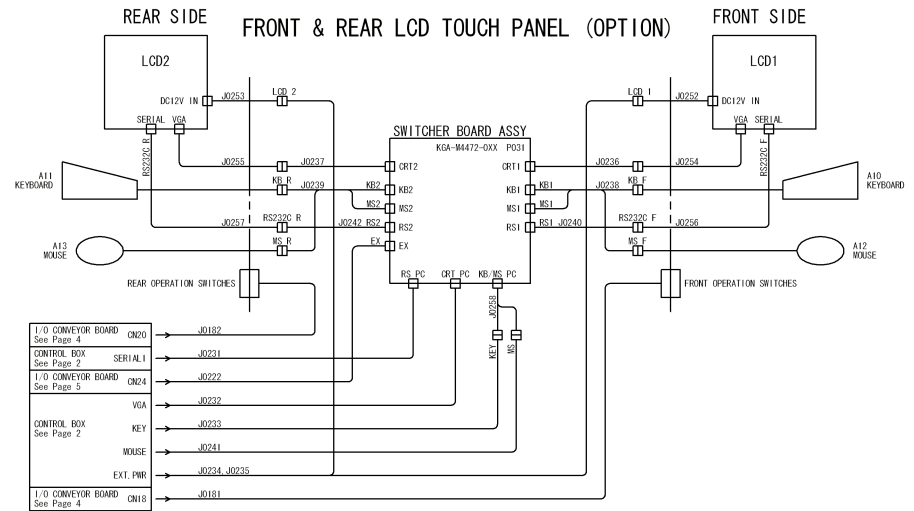
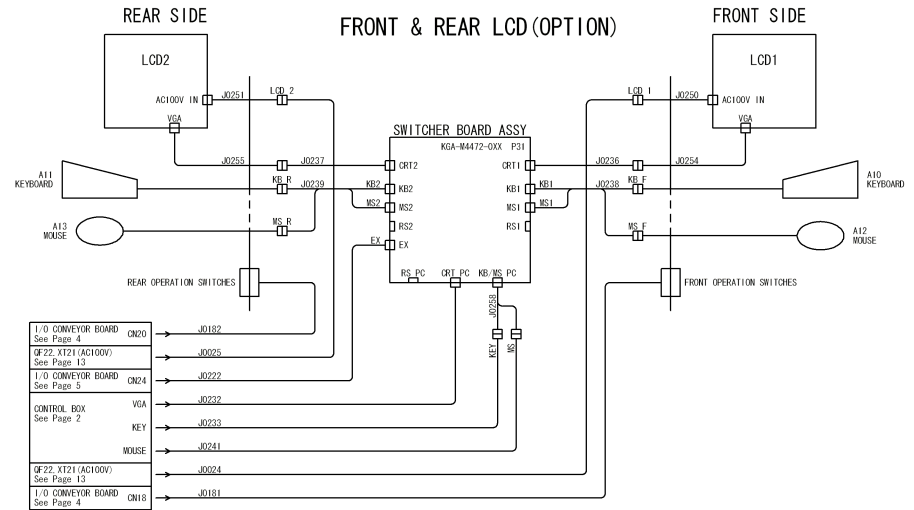
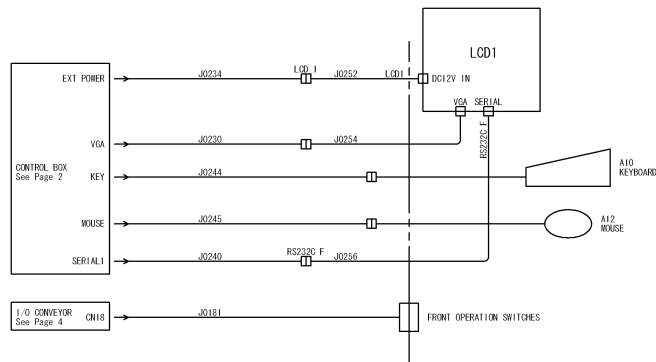

FIX60 FEEDER STRUCTURE

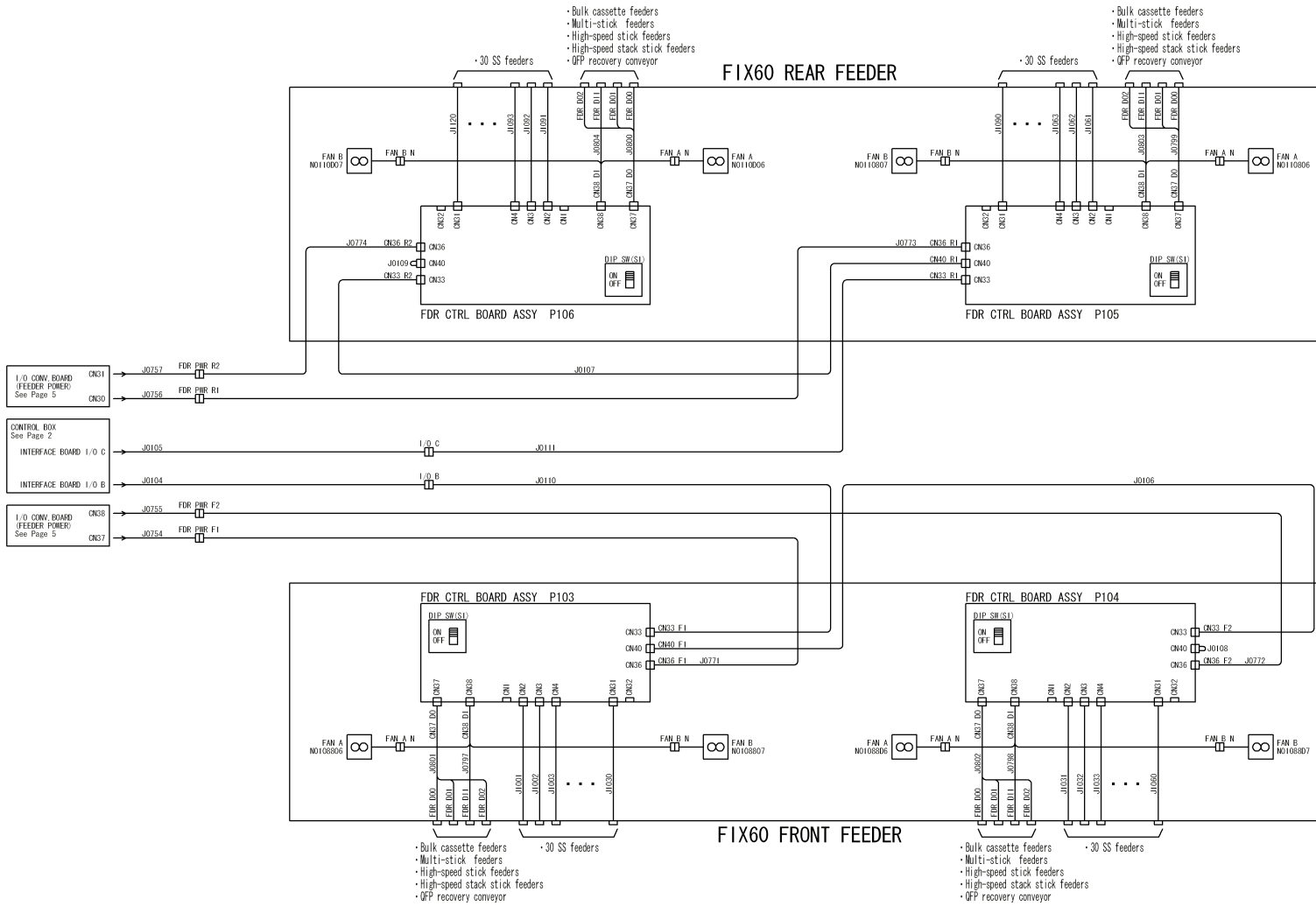

FES24 FEEDER STRUCTURE

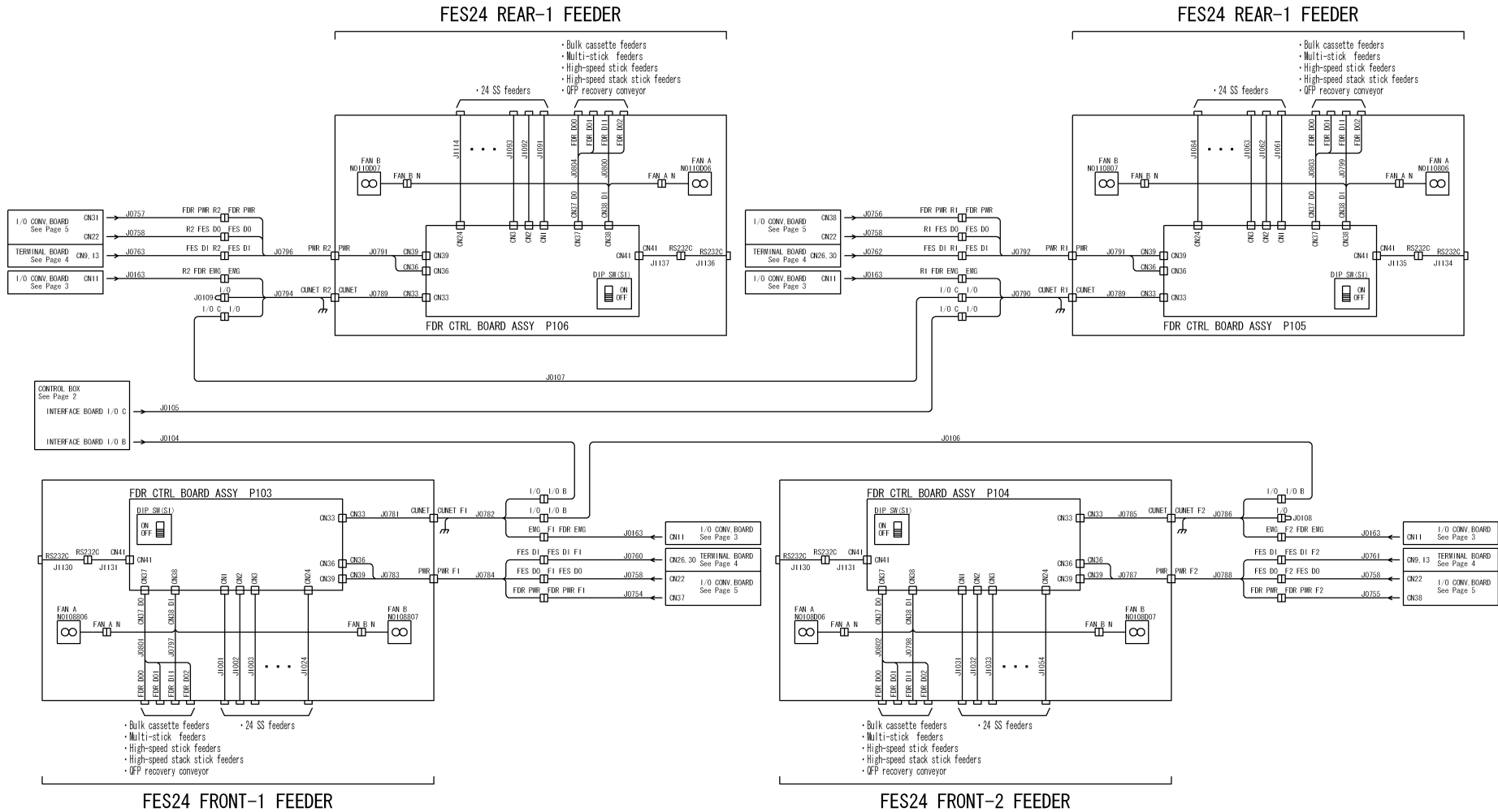

IONIZER ASSY(OPTION)

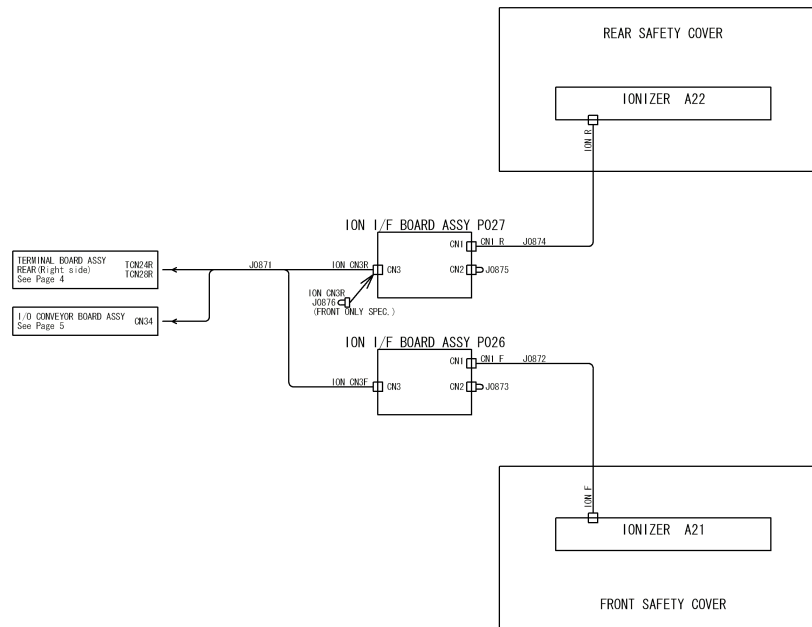

POWER TRANSFORMER

TM11: The selection of POWER SOURCE 1.7KVA

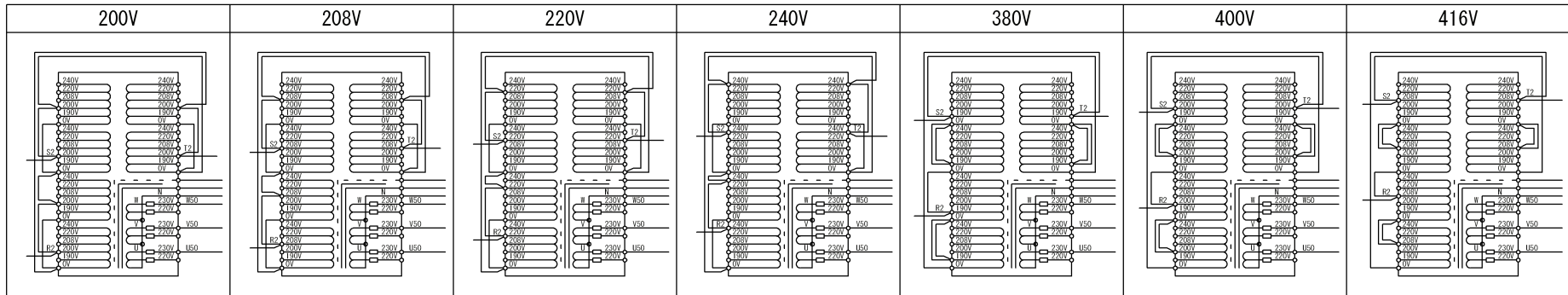

TC11: The selection of POWER SOURCE 1.5KVA (STD)/1.75KVA (with UPS)

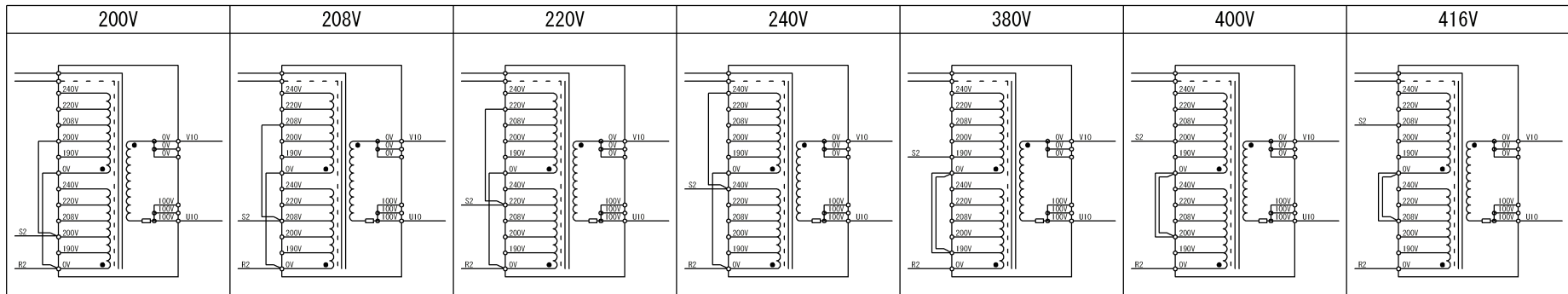

POWER CIRCUIT

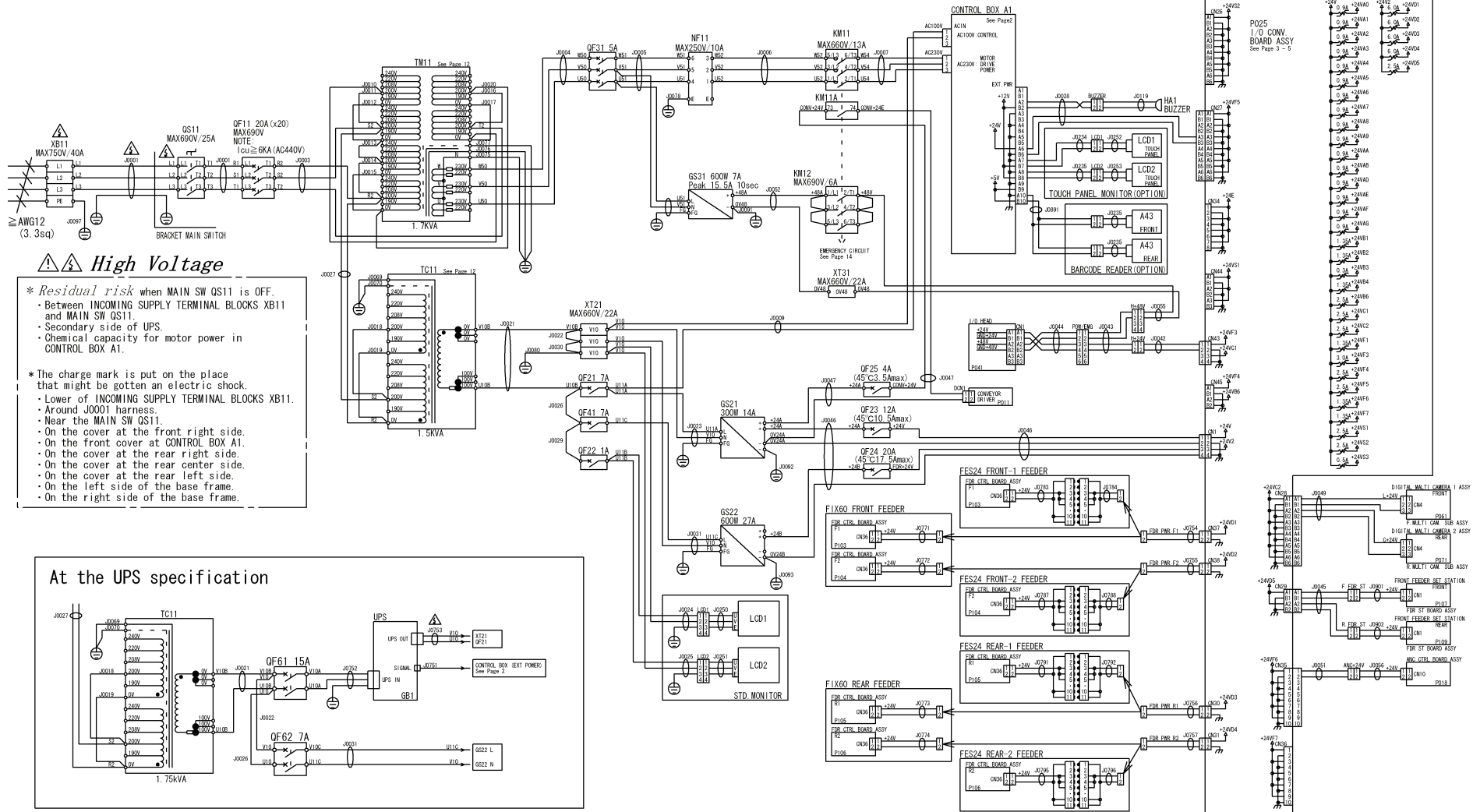

High Voltage

* *Residual risk* when MAIN SW QS11 is OFF.

- Between INCOMING SUPPLY TERMINAL BLOCKS XB11 and MAIN SW QS11.
- Secondary side of UPS.
- Chemical capacity for motor power in CONTROL BOX A1.

* The charge mark is put on the place that might be gotten an electric shock.

- Lower of INCOMING SUPPLY TERMINAL BLOCKS XB11.
- Around J0001 harness.
- Near the MAIN SW QS11.
- On the cover at the front right side.
- On the front cover at CONTROL BOX A1.
- On the cover at the rear right side.
- On the cover at the rear center side.
- On the cover at the rear left side.
- On the left side of the base frame.
- On the right side of the base frame.

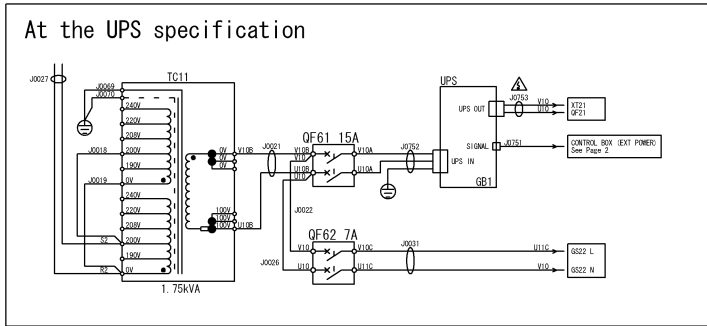

EMERGENCY CIRCUIT

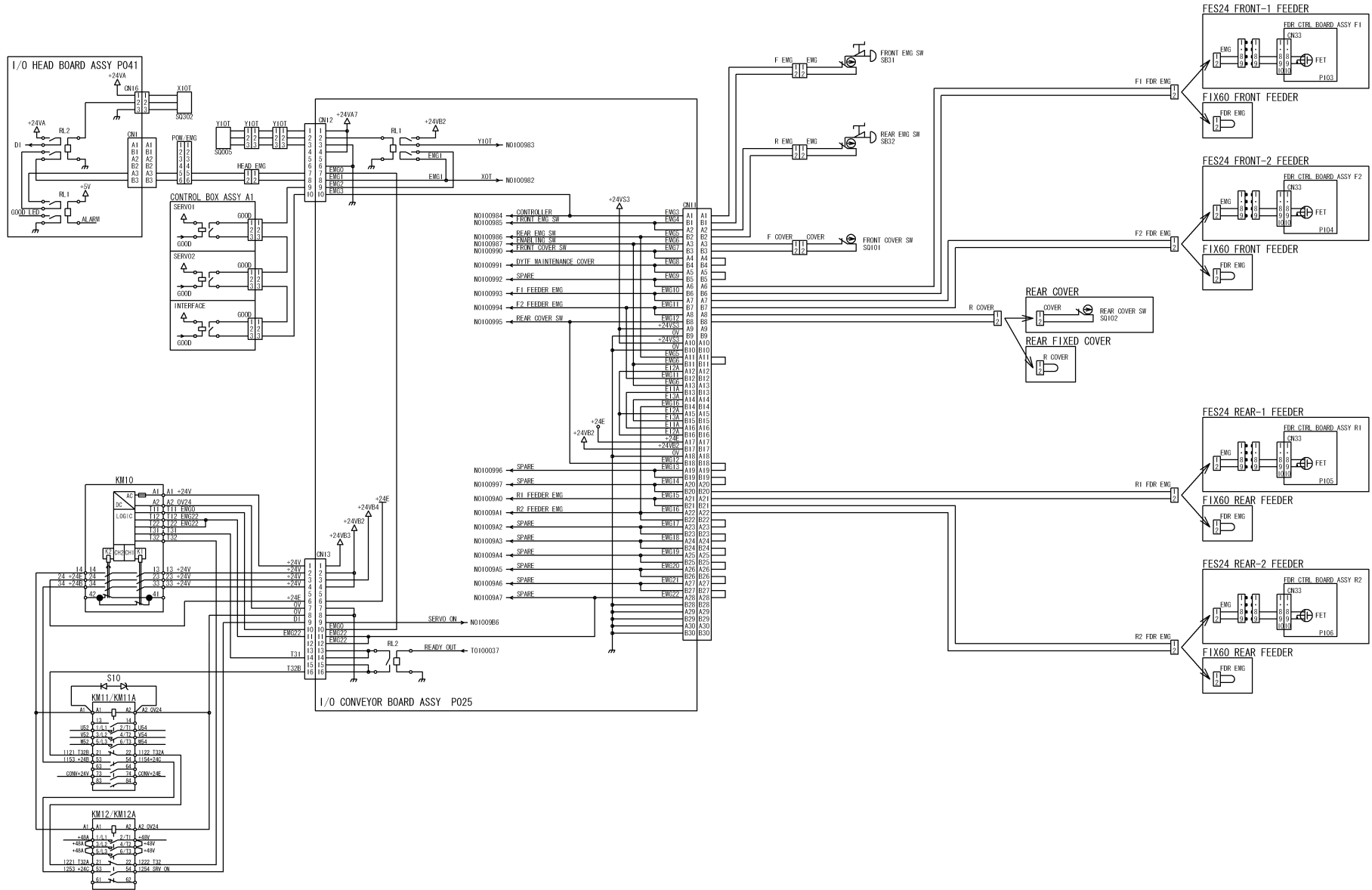

Air circuit (YS12)

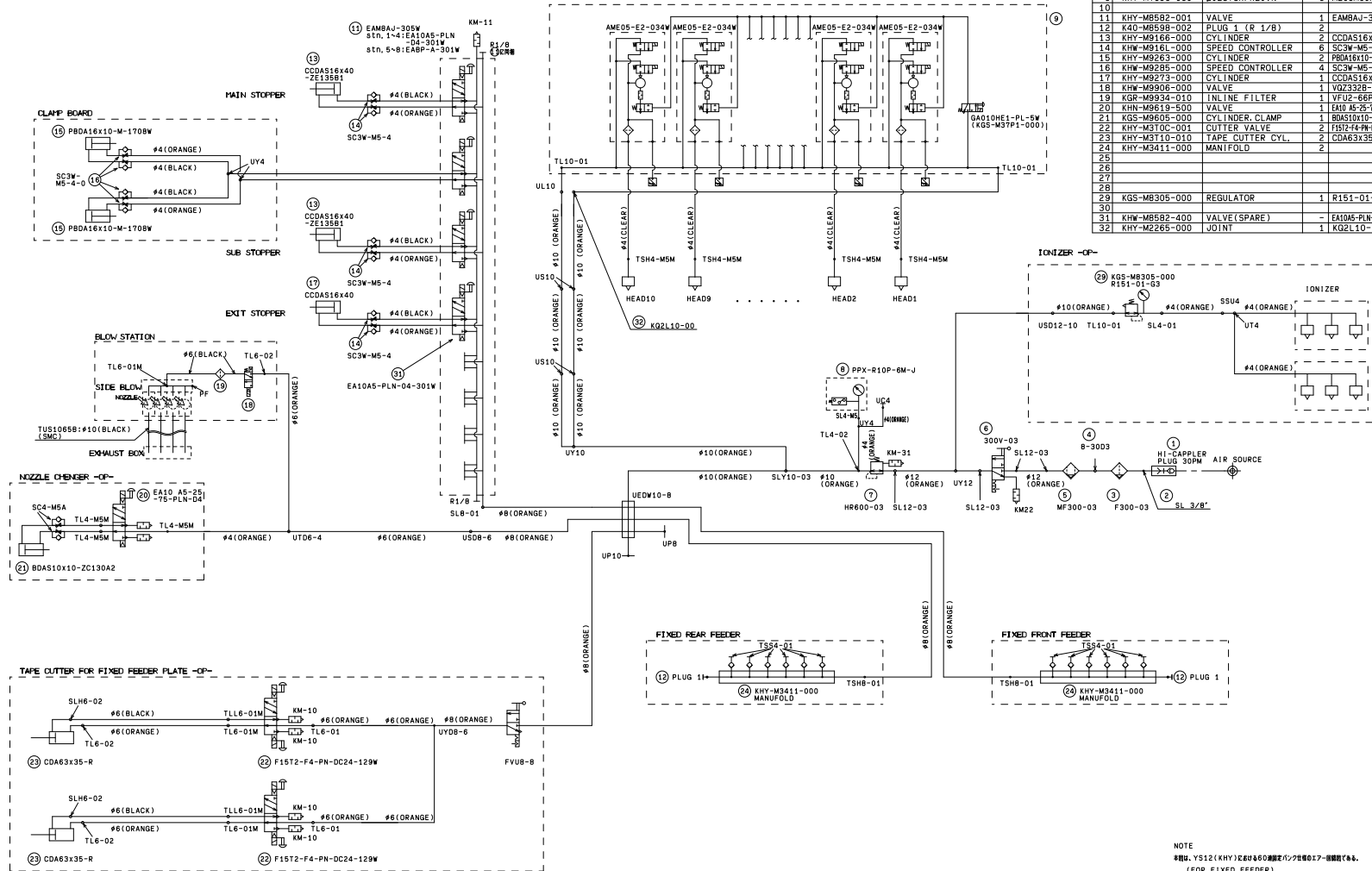

No.	PART NO.	PART NAME	Q'TY	REMARKS
1	90990-42J006	JOINT	1	30PM
2	90990-42J008	JOINT	1	SL 3/8" ELBOW
3	KG7-MB501-000	AIR FILTER	1	F300-03
4	KG7-MB503-000	MODULE ADAPTER	1	B-30D3
5	KG7-MB502-000	MIST FILTER	1	MF300-03
6	KHY-MB501-000	EXHAUST VALVE	1	300V-03
7	KHY-MB504-000	REGULATOR	1	HR600-03
8	KHY-MB596-000	PRESSURE GAUGE	1	PPX-R10P-6M-J
9	KHY-MT151-010	EJECTOR, REJIN	1	ME05M10A-096W
10				
11	KHY-MB582-001	VALVE	1	EAMBAU-305W...
12	K40-MB598-002	PLUG 1 (R 1/8)	2	
13	KHY-M9166-000	CYLINDER	2	CCDAS16x40...
14	KHW-M9161-000	SPEED CONTROLLER	6	SC3W-M5-4
15	KHY-M9263-000	CYLINDER	2	P8M1610-M-1700W
16	KHW-M9285-000	SPEED CONTROLLER	4	SC3W-M5-4-0
17	KHY-M9273-000	CYLINDER	1	CCDAS16x40
18	KHW-M9908-000	VALVE	1	VOZ3328-HG1-C6
19	KGR-M9934-010	INLINE FILTER	1	VFU2-66P-NH
20	KHN-M9619-500	VALVE	1	TAU 45-25-75-PLN-34
21	KGS-M9605-000	CYLINDER CLAMP	1	BDAS10x10-ZC130A2
22	KHY-M310C-001	CUTTER VALVE	2	F15T2-F4-PN-DC24-129W
23	KHY-M3110-010	TAPE CUTTER CYL.	2	CDAS16x40
24	KHY-M3411-000	MANIFOLD	2	CDAS16x40
25				
26				
27				
28	KGS-MB305-000	REGULATOR	1	R151-01-G3
29				
30				
31	KHW-MB582-400	VALVE (SPARE)	-	E10A5-PLN-04-301W
32	KHY-M2265-000	JOINT	1	KQZL10-00

NOTE
 *BL YS12 (KHY)E04860機種の心臓部017-0000(66)
 (FOR FIXED FEEDER)

No	Part No.	Part Name	Q'ty	Remarks
1	KHY-M661A-001	HNS,XB11-QS11	1	J0001
2	KHY-M661L-001	HNS,QF11-TM11	1	J0003
3	KHY-M661E-000	HNS,TM11-QF31	1	J0004
4	KHY-M661F-010	HNS,QF31-NF11.GS31	1	J0005
5	KHY-M661G-000	HNS,NF11-KM11	1	J0006
6	KHY-M661H-001	HNS,C/R AC230V	1	J0007
7	KHY-M661M-000	HNS,C/R AC100V	1	J0009
8	KM6-M66M1-102	HNS,TAP CHANGE	10	J0010-J0019
9	KM6-M66M1-202	HNS,TAP CHANGE	1	J0020
10	KHY-M662A-010	HNS,TC11-QF21 XT21	1	J0021
11	KHW-M66M4-000	HNS,V10 JUMPER	1	J0022
12	KHY-M662E-010	HNS,QF21 XT21-GS21	1	J0023
13	KHW-M662G-000	HNS,LCD POWER 1	1	J0024
14	KHW-M662G-000	HNS,LCD POWER 1	2	J0024,J0025
15	KGA-M662M-001	HNS,U10 JUMPER	1	J0026
16	KHY-M662F-010	HNS,TM11-TC11	1	J0027
17	KHY-M663R-001	HNS,C/R EXT.POWER	1	J0028
18	KGA-M662M-001	HNS,U10 JUMPER	1	J0029
19	KHY-M662E-100	HNS,QF41 XT21-GS22	1	J0031
20	KHY-M663E-000	HNS,I/O HEAD DC24V	1	J0042
21	KHY-M663F-000	HNS,Y-FLEX H.PWR EMG	1	J0043
22	KHY-M663G-000	HNS,X-FLEX H.PWR EMG	1	J0044
23	KHY-M663J-010	HNS,I/O CONV.PWR	1	J0046
24	KHY-M663K-002	HNS,CONV PWR	1	J0047
25	KHY-M66GF-000	HNS,FAN	1	J0048
26	KHY-M663M-000	HNS,MULTI CAM. DC24V	1	J0049
27	KHY-M663N-000	HNS,ANC POWER	1	J0051
28	KHY-M664A-010	HNS,GS31-KM12 XT31	1	J0052
29	KHY-M664F-010	HNS,KM12 +48V	1	J0055
30	KHY-M663V-001	HNS,ANC DC24V	1	J0056
31	KHY-M665A-000	HNS,BRAKE SRV2	1	J0061
32	KHY-M665F-000	HNS,CONV.DRIVER	1	J0062
33	KHW-M665E-000	HNS,CONV. MOTOR	1	J0064
34	90K30-945035	HNS,EARTH	1	J0069
35	90K30-945025	HNS,EARTH	1	J0070
36	KV8-M66L1-001	HNS,FG-C/R	1	J0071
37	90K30-544180	HNS,EARTH	1	J0072
38	90K30-544130	HNS,PE 1300	1	J0073

No	Part No.	Part Name	Q'ty	Remarks
39	90K30-945070	HNS,EARTH	3	J0075,J0076,J0077
40	90K30-245020	HNS,EARTH	1	J0078
41	90K30-245080	HNS,EARTH 800	1	J0080
42	90K30-444100	HNS,EARTH	1	J0081
43	90K30-245060	HNS,EARTH	5	J0083,J0084,J0085,J0086,J0087
44	90K30-255040	HNS,PE 400	1	J0091
45	90K30-255030	HNS,PE 300	1	J0092
46	90K30-377020	HNS,PE 200	1	J0093
47	KHY-M536A-001	HNS,PE	1	J0097
48	90K30-244035	HNS,FG-CNT.BOX	1	J0099
49	KHY-M668A-000	HNS,I/O CMN	1	J0101
50	KHY-M668F-000	HNS,I/O CONV CMN	1	J0102
51	KHY-M66B3-000	HNS,ANC CMN 1	1	J0103
52	KHY-M66RB-000	HNS,FEEDER F1 CMN	1	J0104
53	KHY-M66RB-100	HNS,FEEDER R1 CMN	1	J0105
54	KHY-M66RF-200	HNS,FEEDER COM 2	1	J0106
55	KHY-M66RB-200	HNS,FEEDER CMN 2	2	J0106,J0107
56	KHY-M66RF-200	HNS,FEEDER COM 2	1	J0107
57	KHY-M66RG-000	HNS,TERMINATION	1	J0108
58	KHY-M66X9-000	HNS,TERMINATION	2	J0108,J0109
59	KHY-M66RG-000	HNS,TERMINATION	1	J0109
60	KHY-M66RF-000	HNS,FEEDER I/O	1	J0110
61	KHY-M66RF-000	HNS,FEEDER I/O	1	J0111
62	KHY-M66B3-100	HNS,ANC CMN 2	1	J0112
63	KG2-M669R-113	HNS,BUZZER	1	J0119
64	KGK-M6680-200	HNS,USB-MEMORY 2M AS	1	J0120
65	KHY-M66A1-001	HNS,HEAD SRVB	1	J0121
66	KHY-M66A2-000	HNS,Y-FLEX SRV	1	J0122
67	KHY-M66A3-000	HNS,X-FLEX SRV	1	J0123
68	KHY-M66A4-001	HNS,PI1	1	J0124
69	KHY-M66A5-000	HNS,PI2	1	J0125
70	KHY-M66A6-001	HNS,Y-FLEX X1P	1	J0127
71	KHW-M66A8-000	HNS,BASE W1P	1	J0128
72	KHW-M66A9-000	HNS,BASE PUP	1	J0129
73	KHY-M66AA-000	HNS,BASE Y1P	1	J0130
74	KHY-M66AE-000	HNS,BASE Y2P	1	J0131
75	KHY-M66A7-000	HNS,Y-FLEX SCP	1	J0133
76	KHY-M66AF-000	HNS,X-FLEX SCP	1	J0134

No	Part No.	Part Name	Q'ty	Remarks
77	KHY-M66A0-000	HNS,I/F SRVA	1	J0135
78	KHY-M66E1-010	HNS,MO1	1	J0141
79	KHY-M66E4-010	HNS,MO2	1	J0142
80	KHY-M66E3-000	HNS,Y-FLEX X1M	1	J0143
81	KHY-M66E5-010	HNS,XY-FLEX SCM	1	J0145
82	KHY-M66E5-010	HNS,XY-FLEX SCM	2	J0145,J0146
83	KHY-M66E5-010	HNS,XY-FLEX SCM	1	J0146
84	KHY-M66F2-000	HNS,HEAD C/R EMG	1	J0162
85	KHY-M66F3-010	HNS,EMG	1	J0163
86	KHY-M66F4-011	HNS,CONTACTOR 1	1	J0164
87	KHY-M66F5-010	HNS,CONTACTOR 2	1	J0165
88	KGA-M667J-002	HNS,EMG SW	2	J0166,J0167
89	KHY-M667A-000	HNS,COVER LIMIT	1	J0168
90	KHY-M667A-100	HNS,COVER LIMIT	2	J0168,J0169
91	KHY-M66F6-000	HNS,EMG SHORT	4	J0174,J0175,J0176,J0177
92	KHY-M66F6-100	HNS,R.COVER SHORT	1	J0178
93	KHY-M66G1-000	HNS,F.OPE.PANEL	1	J0181
94	KHY-M66G1-100	HNS,R.OPE.PANEL	1	J0182
95	KHY-M66H4-000	HNS,FDR SW F1	1	J0183
96	KHY-M66G6-000	HNS,SMEMA	1	J0185
97	KHY-M66N3-000	HNS,LE-OUT 1	1	J0186
98	KHY-M66N4-000	HNS,LE-OUT 2	1	J0187
99	KHY-M66GA-000	HNS,Y-FLEX YORG OT	1	J0190
100	KHY-M66GE-000	HNS,CONV.TERMINAL F	1	J0191
101	KHY-M66GE-100	HNS,CONV.TERMINAL R	1	J0193
102	KHY-M66GH-000	HNS,AIR PRESSURE	1	J0194
103	KHY-M66H7-000	HNS,BLOW VALVE	1	J0195
104	KHY-M66JP-000	HNS,ANC OPEN/UP	1	J0196
105	KW3-M66GW-003	HNS,NEXT INTERFACE	1	J0198
106	KKE-M66GX-001	HNS,PRE.INTERFACE 2	1	J0199
107	KHY-M666A-000	HNS,FEE.FLOAT SHORT	6	J0200,J0201,J0202,J0203,J0204,J0205
108	KHY-M666A-000	HNS,FEE.FLOAT SHORT	5	J0201,J0202,J0203,J0204,J0205
109	KHY-M666A-000	HNS,FEE.FLOAT SHORT	4	J0201,J0202,J0204,J0205
110	KHY-M666A-000	HNS,FEE.FLOAT SHORT	2	J0201,J0204
111	KGA-M669V-040	HNS,SWITCH ACTIVE	1	J0207/J0213
112	KGA-M669V-241	HNS,SWITCH START	1	J0208/J0214
113	KGA-M669V-321	HNS,SWITCH STOP	1	J0209/J0215
114	KHA-M669V-030	HNS,SWITCH STOP	1	J0209/J0215

No	Part No.	Part Name	Q'ty	Remarks
115	KGA-M669V-421	HNS,SWITCH ERR.CLR.	1	J0210/J0216
116	KHA-M669V-121	HNS,SWICTH ERR.CLR.	1	J0210/J0216
117	KGA-M669V-140	HNS,SWITCH READY	1	J0211/J0217
118	KGA-M669V-540	HNS,SWITCH RESET	1	J0212/J0218
119	KHY-M66G4-000	HNS,SIG.TOWER	1	J0221
120	KHY-M66H2-010	HNS,CONV VALVE	1	J0222
121	KHY-M66H3-000	HNS,AMF	1	J0225
122	KHY-M66H6-021	HNS,TAPE CUTTER	1	J0226
123	KHY-M66H9-001	HNS,CUTTER COVER	1	J0227,J0228
124	KU8-M66F5-303	HNS,VGA 3M	1	J0230
125	KU8-M66F5-303	HNS,VGA 3M	1	J0230
126	KW3-M668J-020	HNS,TOUCH PANEL ASSY	1	J0231
127	KU8-M66F5-203	HNS,VGA 2M	1	J0232
128	KHY-M6640-000	HNS,KEYBOARD ASSY	1	J0233
129	KHY-M663H-010	HNS,LCD POWER 1	1	J0234
130	KHY-M663H-010	HNS,LCD POWER 1	2	J0234,J0235
131	KU8-M66F5-303	HNS,VGA 3M	1	J0236
132	KU8-M66F5-503	HNS,VGA 5M	1	J0237
133	KGA-M6640-001	HNS,SWITCHER IN1 ASS	1	J0238
134	KGA-M6640-001	HNS,SWITCHER IN1 ASS	1	J0238
135	KGA-M6640-102	HNS,SWITCHER IN2 ASS	1	J0239
136	KGT-M6680-011	HNS,SERIAL 3M ASSY	1	J0240
137	KGT-M6680-011	HNS,SERIAL 3M ASSY	1	J0240
138	KHY-M6640-100	HNS,MOUSE ASSY	1	J0241
139	KGK-M6681-000	HNS,SERIAL 4M ASSY	1	J0242
140	KGA-M664T-300	HNS,SWITCHER IN KB1	1	J0244
141	KGA-M664U-300	HNS,SWITCHER IN MS1	1	J0245
142	KHW-M662G-101	HNS,LCD POWER 2	1	J0250/J0251
143	KHW-M662H-101	HNS,LCD POWER 2	1	J0252/J0253
144	KU8-M66F5-203	HNS,VGA 2M	1	J0254/J0255
145	KGT-M6681-101	HNS,SERIAL 2M ASSY	1	J0256/J0257
146	KHN-M4275-001	HNS,KEY/MOUSE	1	J0258
147	KHY-M66KA-000	HNS,FID LIGHT 1	1	J0300
148	KHY-M66KA-100	HNS,FID LIGHT 2	1	J0301
149	KHY-M663T-001	HNS,H.CAMERA DC24V	1	J0302
150	KHY-M66J2-000	HNS,HEAD VAC SENSOR	1	J0304
151	KHY-M66J3-013	HNS,HEAD DO	1	J0305
152	KHY-M66J7-010	HNS,EARTH 80	1	J0306

No	Part No.	Part Name	Q'ty	Remarks
153	KHY-M66JA-040	HNS,SCAN FLEX	1	J0307
154	KHY-M66J5-140	HNS,Z LINEAR PI 1	5	J0310,J0311,J0312,J0313,J0314
155	KHY-M66J5-300	HNS,Z LINEAR PI 2	5	J0315,J0316,J0317,J0318,J0319
156	KHY-M66J6-040	HNS,SC LINEAR PI	1	J0320
157	KHY-M66KA-210	HNS,FID LIGHT SHORT	1	J0321
158	KHY-M66KA-210	HNS,FID LIGHT SHORT	2	J0321,J0322
159	KHY-M66K2-000	HNS,MULTI CAMERA	1	J0501,J0507
160	KHY-M66K0-010	HNS,Y-FLEX CAM.EXT	1	J0502
161	KHY-M66K1-020	HNS,X-FLEX CAM.EXT	1	J0503
162	KHY-M66K3-001	HNS,FID1 CAMERA	1	J0504
163	KHY-M66K3-101	HNS,FID2 CAMERA	1	J0505
164	KJJ-M66N2-000	HNS,M.LIGHT COAX.	1	J0508,J0511
165	KJJ-M66N9-010	HNS,M.LIGHT SUB CX.	1	J0509,J0512
166	KJJ-M66NA-010	HNS,M.LIGHT MAIN	1	J0510,J0513
167	KHY-M66N2-000	HNS,SCAN LIGHT	1	J0514,J0519,J0520
168	KHY-M66BE-100	HNS,VISION TRG	1	J0530
169	KHY-M66BE-100	HNS,VISION TRG	1	J0531
170	KJJ-M664N-002	HNS,UPS SIGNAL	1	J0751
171	KJJ-M662H-000	HNS,UPS POWER IN	1	J0752
172	KJJ-M662G-001	HNS,UPS POWER OUT	1	J0753
173	KHY-M66RA-000	HNS,FDR PWR F1	1	J0754
174	KHY-M66RA-100	HNS,FDR PWR F2	1	J0755
175	KHY-M66RA-200	HNS,FDR PWR R1	1	J0756
176	KHY-M66RA-300	HNS,FDR PWR R2	1	J0757
177	KHY-M66RC-000	HNS,FES DO	1	J0758
178	KHY-M66RD-000	HNS,FES DI F1	1	J0760
179	KHY-M66RD-100	HNS,FES DI F2	1	J0761
180	KHY-M66RD-200	HNS,FES DI R1	1	J0762
181	KHY-M66RD-300	HNS,FES DI R2	1	J0763
182	KHY-M66T3-010	HNS,FES VALVE	1	J0767
183	KHY-M66RE-000	HNS,FDR PWR F1 R1	1	J0771
184	KHY-M66RE-100	HNS,FDR PWR F2 R2	1	J0772
185	KHY-M66RE-000	HNS,FDR PWR F1 R1	1	J0773
186	KHY-M66RE-100	HNS,FDR PWR F2 R2	1	J0774
187	KHY-M66RJ-000	HNS,REAR FEEDER SW	1	J0775
188	KGB-M3992-003	SWITCH,SELECT	4	J0777,J0778,J0779,J0780
189	KHY-M66R4-000	HNS,FES.CUNET	1	J0781/J0785/J0789/J0793
190	KHY-M66R2-003	HNS,CLAMP MKY F1 R1	1	J0782

No	Part No.	Part Name	Q'ty	Remarks
191	KHY-M66R5-000	HNS,FES.PWR	1	J0783/J0787/J0791/J0795
192	KHY-M66R3-000	HNS,CLAMP PWR F1,R1	1	J0784
193	KHY-M66R2-102	HNS,CLAMP MKY F2,R2	1	J0786
194	KHY-M66R3-100	HNS,CLAMP PWR F2,R2	1	J0788
195	KHY-M66R2-003	HNS,CLAMP MKY F1 R1	1	J0790
196	KHY-M66R3-000	HNS,CLAMP PWR F1,R1	1	J0792
197	KHY-M66R2-102	HNS,CLAMP MKY F2,R2	1	J0794
198	KHY-M66R3-100	HNS,CLAMP PWR F2,R2	1	J0796
199	KHY-M66RL-120	HNS,FDR DI FIX	2	J0797,J0798
200	KHY-M66RL-030	HNS,FDR DI FES	1	J0797/J0798/J0799/J0800
201	KHY-M66RL-120	HNS,FDR DI FIX	2	J0799,J0800
202	KJJ-M66RM-211	HNS,FDR DO FIX-L	1	J0801
203	KHY-M66RM-001	HNS,FDR DO FES	1	J0801/J0802/J0803/J0804
204	KHY-M66RM-101	HNS,FDR DO FIX-R	1	J0802
205	KJJ-M66RM-211	HNS,FDR DO FIX-L	1	J0803
206	KHY-M66RM-101	HNS,FDR DO FIX-R	1	J0804
207	KHY-M6671-010	HNS,ION 1	1	J0871
208	KHY-M6673-000	HNS,ION 3	1	J0872
209	KHY-M6673-000	HNS,ION 3	2	J0872,J0874
210	KHY-M6675-000	HNS,ION SHORT	1	J0873
211	KHY-M6675-000	HNS,ION SHORT	2	J0873,J0875
212	KHY-M6676-000	HNS,ION SHORT R	1	J0876
213	KGA-M66X3-013	HNS,RS232C-BCR-F	1	J0876/J0892
214	KGA-M66X3-113	HNS,RS232C-BCR-R	1	J0877/J0893
215	KHY-M66Y8-000	HNS,E.COM POWER	1	J0891
216	KHY-M66TE-002	HNS,F.CTRL - FDR	24	J1001-24/J1031-54/J1061-84/J1091-114
217	KHY-M66TE-002	HNS,F.CTRL - FDR	60	J1001-J1060
218	KHY-M66TE-002	HNS,F.CTRL - FDR	60	J1061-J1120
219	KHJ-M668A-000	HNS,RS232C	1	J1130/J1132/J1134/J1136
220	KHJ-M668A-100	HNS,CN41-RS232C	1	J1131/J1133/J1135/J1137
221				
222				
223				
224				
225				
226				
227				
228				